

## 1172 Argon - LED COB

Corpo: In alluminio pressofuso, con ampie alettature di raffreddamento.  
 Riflettore: In alluminio stampato prismatizzato, ossidato anodicamente con sp. 3 µ e brillantato per un elevato rendimento luminoso.  
 Diffusore: vetro di protezione temperato, spessore 5 mm resistente agli shock termici e agli urti  
 Dotazione: Completo di connettore stagno IP67 per il collegamento alla linea.  
 LED:  
 15900lm - 5000K - 115W - CRI>70  
 14000lm - 4000K - 115W - CRI>80  
 Mantenimento del flusso luminoso al 70%: 50000h L70B50.  
 Classificazione rischio fotobiologico: Gruppo esente  
 Classe di isolamento I e grado di protezione IP65-IK08 secondo le EN 60598-1.

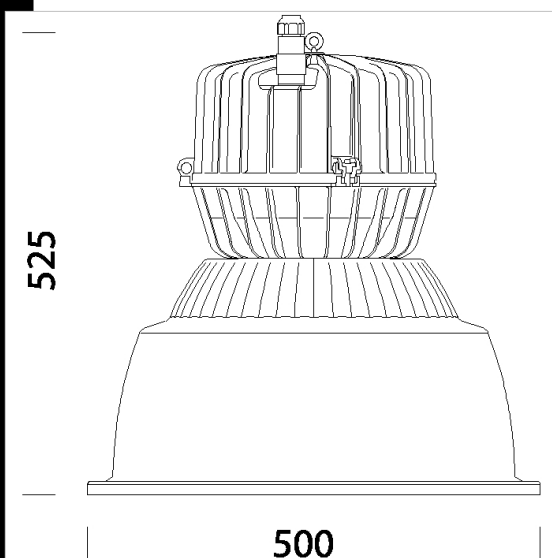

Codice	Cablaggio	Kg	Watt	Attacco base	Lampade	Colore
322652-00	CLD CELL	7,16	LED COB	-	15900lm-5000K-CRI>70	ARGENTO SABBBIATO
322653-00	CLD CELL	8,24	LED COB 115W		14000lm-4000K-CRI 80	ARGENTO SABBBIATO

### Accessori



- 1122 Gabbia

IK08	CLD CELL	
	CE	IP65
	UV	
		
		
RG0	+30 C° -20	

### Download

DXF 2D  
- 1172i.dxf