

FEATURES

- DC to 4 GHz
- Power to 800 W
- Climatic category 60/150/56

GENERAL SPECIFICATIONS

■ Operating Temp. Range:	-60 °C to 150 °C
■ Load Life 100 °C/ 1000 h:	5 %
■ Max. Resistance Change at Rated Dissipation $ \Delta R/R \text{ max.} $ after 25000 h	10 %
■ Package:	Flanged, leaded chip
■ Process:	Thin film
■ Resistive Material:	Ta
■ Substrate Material:	AlN
■ Coating:	Enamel
■ Mounting Flange:	Cu, Ni plated
■ Leads:	Cu, Sn-Pb plated

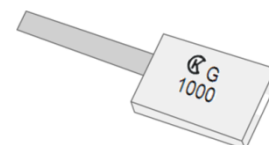
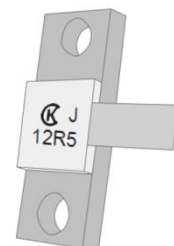
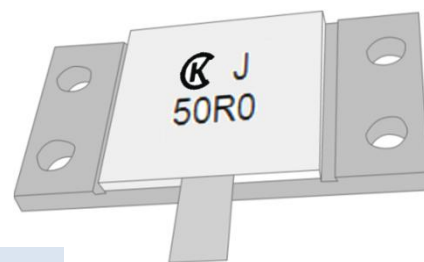

Part Number	Power (W)	Frequency (GHz)	Resistance Value (Ohms)	Resistance Tolerance (\pm %)	Temperature Coefficient (ppm/°C)
PR1-21-10	10	4	50, 100	5, 2	\pm 200
PR1-21-30	30	4	12.5, 25, 37.5, 50 75, 100	5, 2, 1	\pm 200 \pm 500
PR1-21-75	75	2	12.5, 25, 37.5, 50 75, 100	5, 2, 1	\pm 200 \pm 500
PR1-21-150	150	1	12.5, 25, 37.5, 50, 75, 100	5, 2, 1	\pm 200
PR1-21-250	250	0,8	12.5, 25, 37.5, 50, 75, 100	5	\pm 200
PR1-21-400	400	0,5	12.5, 25, 37.5, 50, 75, 100	5	\pm 200
PR1-21-630	630	0,3	12.5, 25, 37.5, 50 75, 100, 150	5, 2	\pm 200 \pm 500
PR1-21-800	800	0,1	12.5, 25, 37.5, 50 75, 100, 150	5, 2	\pm 200 \pm 500

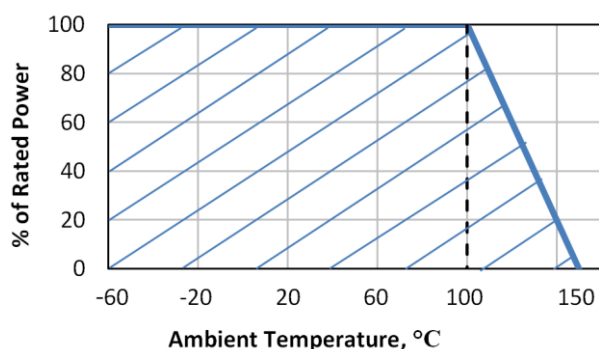

PART NUMBER CODE

PR1-21

model

800

power
10...800

F0

package
Fx - flanged
Lx - leaded

50R0

value
12R5 = 12.5 Ω
1500 = 150 Ω

F

tolerance
F = 1 %
G = 2 %
J = 5 %

PR1-21-030-F0-xxxx-x PR1-21-075-F0-xxxx-x

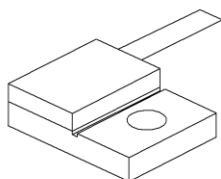
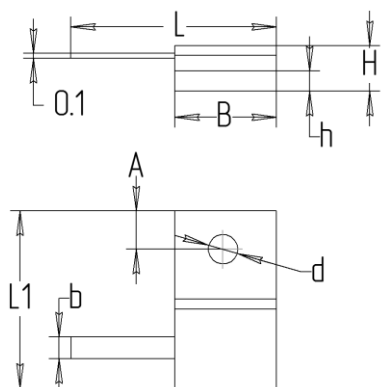

Power (W)	Frequency (GHz)	Resistance value (Ohms)	Tolerance (%)	TC (ppm/°C)
30	4	12.5, 25, 37.5, 50	5, 2, 1	±200
		75, 100		±500
75	2	12.5, 25, 37.5, 50	5, 2, 1	±200
		75, 100		±500

Part Number	Dimensions (mm)											Mass (g)
	L	L1	B	b	H	h	A	Ød				
PR1-21-030-F0	14.5±3	13	+0.50 -0.43	6	+0.50 -0.12	1±0.14	3.5	+0.5 -0.2	1.7 _{-0.25}	3±0.1	2.8±0.25	2
PR1-21-075-F0	17.5±3	14	+0.50 -0.43	9	+0.50 -0.15	1±0.14	5	+0.5 -0.2	3.2 _{-0.3}	3.8±0.12	4.1±0.30	4

PR1-21-030-F1-xxxx-x

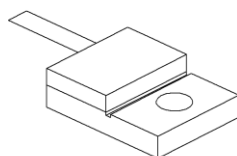
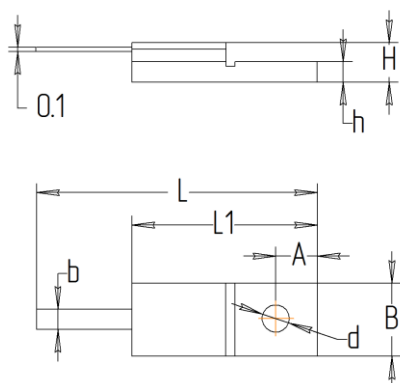

Power (W)	Frequency (GHz)	Resistance value (Ohms)	Tolerance (%)	TC (ppm/°C)
30	4	12.5, 25, 37.5, 50	5, 2, 1	±200
		75, 100		±500

Part Number	Dimensions (mm)											Mass (g)
	L	L1	B	b	H	h	A	Ød				
PR1-21-030-F1	21.5±3	13	+0.50 -0.43	6	+0.50 -0.12	1±0.14	3.5	+0.5 -0.2	1.7 _{-0.25}	3±0.1	2.8±0.25	2

PR1-21-150-F0-xxxx-x

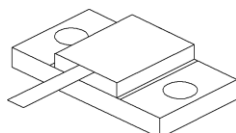
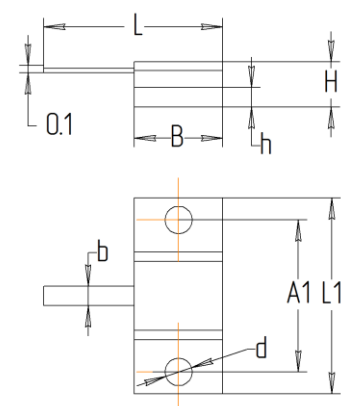

Power (W)	Frequency (GHz)	Resistance value (Ohms)	Tolerance (%)	TC (ppm/°C)
150	1	12.5, 25, 37.5, 50	5, 2, 1	±200
		75, 100		

Part Number	Dimensions (mm)											Mass (g)	
	L	L1	B	b	H	h	A1	Ød					
PR1-21-150-F0	17.5±3	22	+0.50 -0.21	9	+0.30 -0.1	1.6±0.14	3.8	+0.5 -0.4	2	+0.3 -0.1	16±0.1	3.4 ^{+0.3}	4

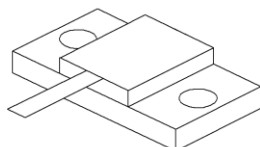
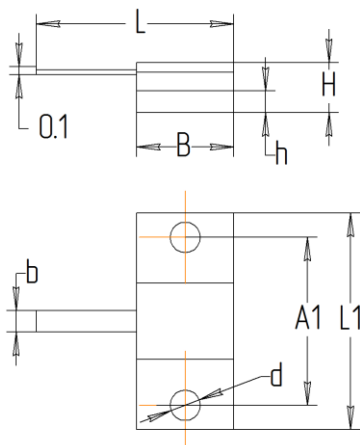

PR1-21-250-F0-xxxx-J

PR1-21-400-Fx-50R0-J

Power (W)	Frequency (GHz)	Resistance value (Ohms)	Tolerance (%)	TC (ppm/°C)
250	0.8	12.5, 25, 37.5, 50	5	±200
		75, 100		
400	0.5	12.5, 25, 37.5, 50	5	±200
		75, 100		

Part Number	Dimensions (mm)											Mass (g)
	L	L1	B	b	H	h	A1	∅d				
PR1-21-250-F0	18.5±3	24	+0.5 -0.21	9	+0.3 -0.1	4±0.24	4.4	+0.5 -0.2	2.8 ^{+0.3}	18±0.1	3.4 ^{+0.3}	6.5
PR1-21-400-F0	19.5 +4 -3	28	+0.5 -0.21	12.7	+0.3 -0.18	6±0.24	4.6	+0.5 -0.2	2.9 +0.3 -0.1	20.3±0.1	4.2 ^{+0.12}	10.5
PR1-21-400-F1	19.5 +4 -3	28	+0.5 -0.21	12.7	+0.3 -0.18	4±0.24	5.1	+0.5 -0.2	2.9 +0.3 -0.1	20.3±0.1	4.2 ^{+0.12}	10.5

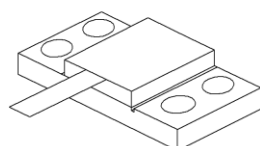
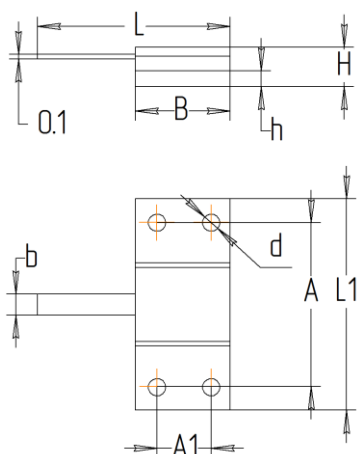

PR1-21-630-F0-xxxx-x

PR1-21-800-F0-xxxx-x

Power (W)	Frequency (GHz)	Resistance value (Ohms)	Tolerance (%)	TC (ppm/°C)
630	0.3	12.5, 25, 37.5, 50	5, 2	±200 ±500
		75, 100		
800	0.1	12.5, 25, 37.5, 50	5, 2	±200 ±500
		75, 100		

Part Number	Dimensions (mm)											Mass (g)	
	L	L1	B	b	H	h	A	A1	∅d				
PR1-21-630-F0	29.5±3	42	+0.50 -0.62	19	+0.50 -0.21	6±0.24	4.8	+0.5 -0.2	3.0 _{0.3}	34±0.25	11	3.2±0.3	26
PR1-21-800-F0	35.5±3	48	+0.50 -0.62	25	+0.50 -0.21	6±0.24	5	+0.5 -0.2	3.2 _{0.3}	39.4±0.25	12.7	4.2±0.3	40

PR1-21-xxx-Lx-xxxx-x

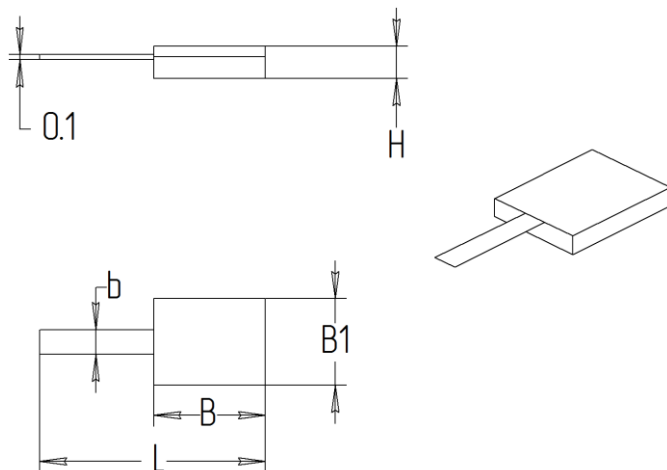

Power (W)	Frequency (GHz)	Resistance value (Ohms)	Tolerance (%)	TC (ppm/°C)
10	4	50, 100	5, 2	±200
30	4	12.5, 25, 37.5, 50 75, 100	5, 2, 1	±200 ±500
75	2	12.5, 25, 37.5, 50 75, 100	5, 2, 1	±200 ±500
150	1	12.5, 25, 37.5, 50 75, 100	5, 2, 1	±200
250	0.8	12.5, 25, 37.5, 50 75, 100	5	±200
400	0.5	50	5	±200
630	0.3	12.5, 25, 37.5, 50 75, 100	5, 2	±200 ±500
800	0.1	12.5, 25, 37.5, 50 75, 100	5, 2	±200 ±500

Part Number	Dimensions (mm)						Mass (g)
	L	B	B1	b	H		
PR1-21-010-L0	14±2	5 ^{+0.4} _{-0.2}	2.5 ^{+0.4} _{-0.2}	1±0.14	1.3 ^{+0.5} _{-0.2}	0.6	
PR1-21-030-L0	14.5±3	6 ^{+0.5} _{-0.12}	6 ^{+0.5} _{-0.12}	1±0.14	1.8 ^{+0.5} _{-0.2}	1.1	
PR1-21-075-L0	17.5±3	9 ^{+0.5} _{-0.15}	6 ^{+0.5} _{-0.15}	1±0.14	1.8 ^{+0.5} _{-0.2}	1.1	
PR1-21-150-L0	17.5±3	9 ^{+0.5} _{-0.4}	6 ^{+0.5}	1.6±0.14	1.3 ^{+0.5} _{-0.2}	1.5	
PR1-21-250-L0	18.5±3	9 ^{+0.3} _{-0.1}	9 ^{+0.3} _{-0.1}	4±0.24	1.3 ^{+0.5} _{-0.2}	2.3	
PR1-21-400-L0	19.5 ⁺⁴ ₋₃	12.7 ^{+0.3} _{-0.18}	12.7 ^{+0.3} _{-0.1}	6±0.24	1,6 ^{+0.5} _{-0.2}	5.6	
PR1-21-400-L1	19.5 ⁺⁴ ₋₃	12.7 ^{+0.3} _{-0.18}	12.7 ^{+0.3} _{-0.1}	4±0.24	2,1 ^{+0.5} _{-0.2}	5.6	
PR1-21-630-L0	29.5±3	19 ^{+0.5} _{-0.21}	19 ^{+0.5} _{-0.21}	6±0.24	1.8 ^{+0.5} _{-0.2}	6.3	
PR1-21-800-L0	35.5±3	25 ^{+0.5} _{-0.21}	25 ^{+0.5} _{-0.21}	6±0.24	1.8 ^{+0.5} _{-0.2}	15.4	

MOUNTING PROCEDURE

For flanged:

1. The underside of the flange should be brushed with thermal grease.
2. Termination should be fastened to the heat sink with screws.
3. Torque screws to the appropriate value.
4. Solder lead in place using appropriate solder with a controlled temperature iron.

For leaded chips:

1. Solder chip and lead in place using appropriate solder with a controlled temperature iron.

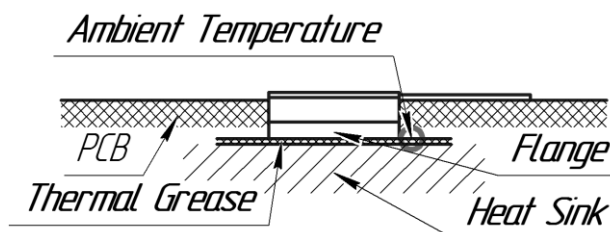

** FOR MORE DETAILS CONTACT FACTORY **

PERFORMANCE CHARACTERISTICS

Test	Condition	ΔR max.
Robustness of termination	IEC60115-1 (4.16)/ IEC 60068-2-21 Bending; Tensile	$\pm 2 \%$
Solderability	IEC60115-1 (4.17)/ IEC 60068-2-20 (235 \pm 5) °C; 2 s; solder bath method; SnPb40	Good tinning (>95 % covered, no visible damage)
Resistance to soldering heat	IEC60115-1 (4.18.2)/ IEC 60068-2-20 (260 \pm 5) °C; (5 \pm 1) s	$\pm 2 \%$; no visible damage
Rapid change of temperature	IEC60115-1 (4.19)/ IEC 60068-2-14 30 min at -60 °C; 30 min at 150 °C; 5 cycles	$\pm 5 \%$
Vibration	IEC60115-1 (4.22)/ IEC 60068-2-6 32 sweep cycles per direction; 10 Hz to 2000 Hz; 1 mm; 100 m/s ²	$\pm 2 \%$
Damp heat, steady state	IEC60115-1 (4.24)/ IEC 60068-2-78 (40 \pm 2) °C; 56 days; (93 \pm 3) % RH	$\pm 5 \%$

All tests are carried out in accordance with the following specifications:

- IEC 60115-1 (clause),
- IEC 60068-2-xx (test method).

PACKAGING

Carton box.

MARKING

Nominal value	Marking
12.5 Ω	12R5
25 Ω	25R0
37.5 Ω	37R5
50 Ω	50R0
75 Ω	75R0
100 Ω	1000
150 Ω	1500